



SPX Corporation  
655 Eisenhower Drive  
Owatonna, MN 55060-0995 USA  
Phone: (507) 455-7000  
Tech. Serv.: (800) 533-6127  
Fax: (800) 955-8329  
Order Entry: (800) 533-6127  
Fax: (800) 283-8665  
International Sales: (507) 455-7223  
Fax: (507) 455-7063

Form No. 543068

## Assembly Instructions

for:

6587

# StrutTamer Gear Box

These instructions outline how to assemble No. 6587 Gear Box (2:1 reduction) to No. 6585 StrutTamer HD to make it easier to turn the handle when working with heavy-duty struts.

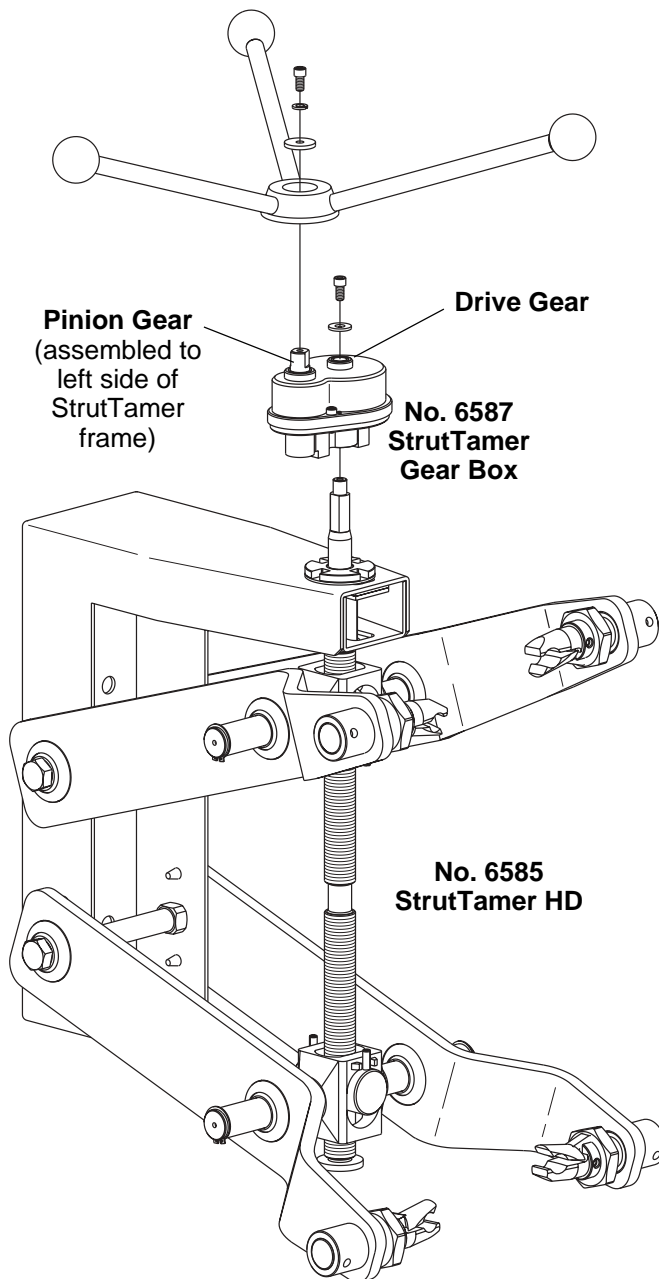

1. Remove the cap screw, lockwasher, washer, spacer, and handle from the top of the StrutTamer. Discard the spacer.
2. Assemble the gear box to the StrutTamer by aligning the drive gear over the forcing screw.

*Note: There are four possible assembly positions for the gear box—use whatever position is most convenient for your application.*

*We recommend mounting the gear box so the pinion gear is on either side of the StrutTamer frame. This offers better support while operating the tool.*

3. Secure the gear box to the forcing screw using the washer and cap screw provided.
4. Position the handle over the pinion gear on the gear box, followed by the washer, lockwasher, and cap screw removed in Step 1.



**CAUTION:** To prevent personal injury, wear eye protection that meets ANSI Z87.1 and OSHA standards.