



SPX Corporation
 655 Eisenhower Drive
 Owatonna, MN 55060-0995 USA
 Phone: (507) 455-7000
 Tech. Serv.: (800) 533-6127
 Fax: (800) 955-8329
 Order Entry: (507) 455-1480
 Fax: (800) 283-8665
 International Sales: (507) 455-7290
 Fax: (507) 455-7063

Form No. 107300

**Parts List &
 Operating Instructions
 for:**

6494

Clamshell Strut Tool
 (for use on MacPherson Struts only)

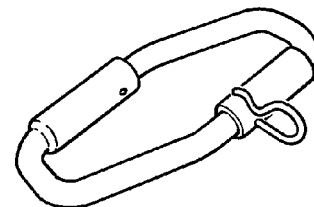
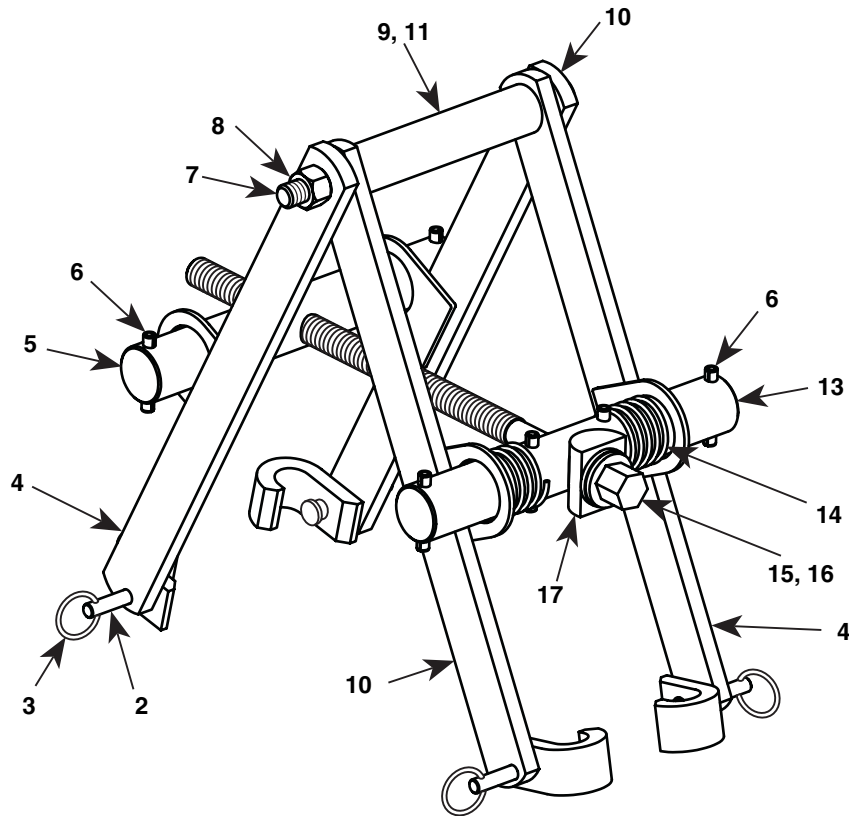

Optional Strut Ring
 (see Sheet 2 of 2, Back)

Important: Do not use this tool without the thrust bearing washer and pivot adapter (Item 16 AND 17) in place, because the forcing screw (Item 15) could cause excessive wear of the trunnion (Item 13) and shorten product life.

Sheet No. 1 of 2

Issue Date: Rev. B, 10-4-02

Item No.	Part No.	No. Req'd	Description
2	217183	4	Clevis Pin (1-3/4" Lg.)
3	213876	4	Split Ring
4	516238	2	Short Hook Frame
5	310334	1	Threaded Trunnion
6	11955	6	Slotted Spring Pin (1/4 x 1-3/4" Lg.)
7	217610	1	Hex Hd. Screw (1/2-13 x 7-1/2" Lg.)
8	15013	1	Locknut (1/2-13)
9	217180	1	Round Spacer
10	516237	2	Long Hook Frame
11	217182	1	Compression Spring
13	513310	1	Plain Trunnion
14	217181	2	Compression Spring
15	310336	1	Forcing Screw

Item No.	Part No.	No. Req'd	Description
16	215842	1	Thrust Bearing Washer
17	513311	1	Pivot Adapter

PARTS INCLUDED BUT NOT SHOWN

515840	1	Logo Decal
217186	1	Warning Decal
106288	1	Application Guide
16473	1	Patent Pending

OPTIONAL

7532	1	Strut Ring
------	---	------------

Refer to any operating instructions included with the product for detailed information about operation, testing, disassembly, reassembly, and preventive maintenance.

Items found in this parts list have been carefully tested and selected by OTC. **Therefore: Use only OTC replacement parts!**

Additional questions can be directed to the OTC Technical Services Department.

Safety Precautions

WARNING: Failure to heed the following warnings can result in personal injury and / or equipment damage. These warnings cannot cover every situation, so have safety foremost in your mind when setting up a job.



- Read, understand, and follow the operating instructions, and the ANSI B30.1 and ASME PALD-1 safety standards for jacks.

If the operator cannot read English, operating instructions and safety precautions must be read and discussed in the operator's native language.

Si el operador no puede leer el inglés, las instrucciones de operación y las precauciones de seguridad deberán leerse y comentarse en el idioma nativo del operador.

Si l'utilisateur ne peut lire l'anglais, les instructions et les consignes de sécurité doivent lui être expliquées dans sa langue maternelle.

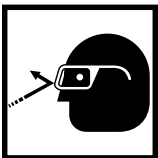

- Wear eye protection that meets the requirements of ANSI Z87.1 and OSHA.
- Use this tool on MacPherson struts only.
- Check the condition of the strut tool before each use; do not use the strut tool if it is in poor condition.



- Spring compression creates a potentially dangerous situation because of the energy trapped between the spring mounts. Before compressing a spring, the hooks must be fully engaged and the retaining pins must be pushed in.
- When compressing a spring, position the hooks around a minimum of four spring coils. Any less than four coils causes the remaining coils to grow, creating pressure on the top mount. Removing the top mount becomes a hazardous procedure.
- Compress the spring only until it is loose in its spring mounts. **DO NOT EXCEED 30 FT. LBS. OF TORQUE ON THE ACTUATING SCREW.** Compressing the spring too far will cause premature tool failure that can result in severe personal injury.
- Do not remove the piston rod nut until the spring is compressed enough to be loose in the mount.
- Do NOT drop the tool while it is holding a spring.

Operating Instructions

Removal

Important: Keep the actuating screw well lubricated.

1. Refer to the vehicle service manual, and follow the manufacturer's recommended procedure to remove the MacPherson strut assembly from the vehicle.
2. Clamp the strut assembly in a vise.
3. Mark the spring in relation to the lower platform and top mount. This notes the correct position for installation.
4. Place two hooks around a coil as close to the top of the spring as possible. **Note: The 3/4" hex on the forcing screw should be up.** Place the other two hooks as close to the bottom of the spring as possible. Push in the four retaining pins. See Figure 1.
5. Using an impact wrench or ratchet with a 3/4" socket on the actuating screw, compress the spring only until it is loose in the spring mount.

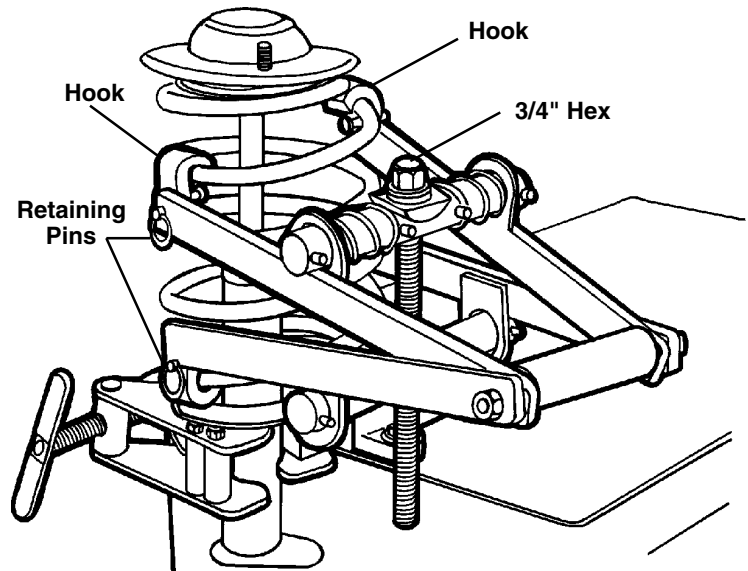

Figure 1

⚠ WARNING: DO NOT EXCEED 30 FT. LBS. OF TORQUE ON THE ACTUATING SCREW. Compressing the spring too far will cause premature tool failure that can result in severe personal injury. Compress the spring only until it is loose in the spring mount.

6. Remove the piston rod nut. Carefully store the tool and spring assembly in a place where it cannot roll off a bench or be dropped.
7. Remove the old strut. Compare the old strut with the new one to be sure you are installing the correct strut. Dispose of the old strut.

Spring Replacement

1. Place the tool and spring assembly on a workbench. Using a ratchet or impact wrench, SLOWLY and carefully decompress the spring.
2. Remove the old spring from the strut tool. Install the new spring in the tool so that a maximum number of coils can be grabbed by the tool without interfering with the spring tip placement in the mounting plates.
3. Compress the spring, and follow the instructions for "Installation."

Installation

1. Position the compressed spring assembly back in place. Align the lower spring tip in its receptacle in the lower platform.
2. Replace the top mount.
3. Attach the piston rod nut, and torque it to the specifications listed in the vehicle service manual.
4. Check the alignment of both spring coil tips to the mounting platforms. Decompress the spring.
5. Refer to the vehicle service manual, and follow the manufacturer's recommended procedure to reinstall the MacPherson strut assembly.

Optional Accessory

1. Clamp the strut tube in a vise.
2. Place the strut ring around the strut tube below the spring and shield, if supplied. See Figure 2.
3. Insert the pin through the ring halves.
4. Place two of the hooks from the clamshell strut tool around a coil as close to the top of the spring as possible. See Figure 3. **Note:** The 3/4" hex on the actuating screw should be up.
5. Position the other two hooks, one on each end of the strut ring.
6. Push in the four retaining pins on the strut tool.
7. Using an impact wrench or ratchet with a 3/4" socket on the actuating screw, compress the spring only until the spring is loose in the spring mount.

⚠ WARNING: Do NOT exceed 30 ft. lbs. of torque on the actuating screw. Compressing the spring too far will cause premature tool failure that can result in severe personal injury. Compress the spring only until it is loose in the spring mount.

8. Remove the piston rod nut.
9. SLOWLY and carefully decompress the spring. Remove the strut tool and ring.

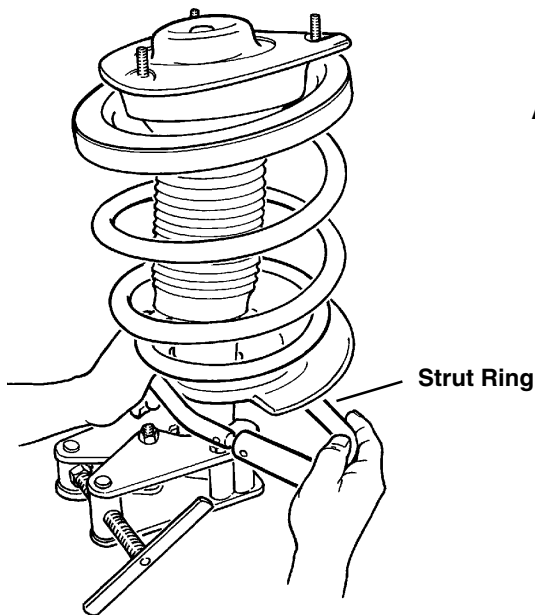

Figure 2

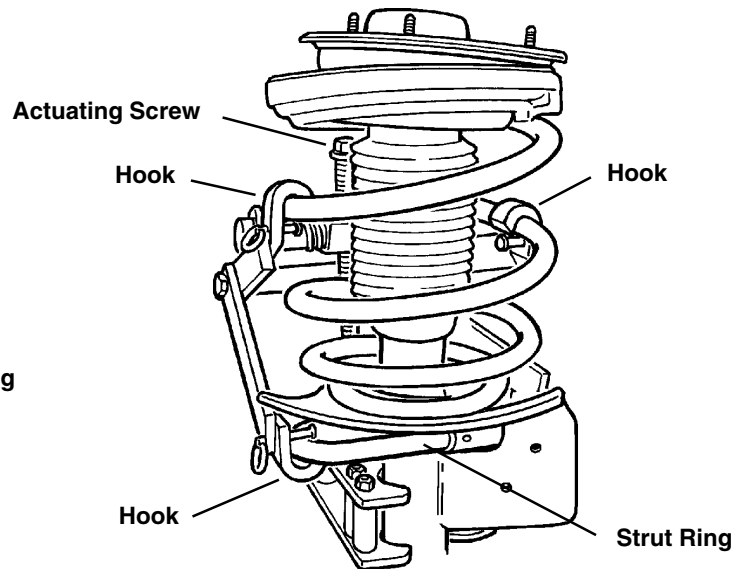

Figure 3