

No. 18548 Tube Bender

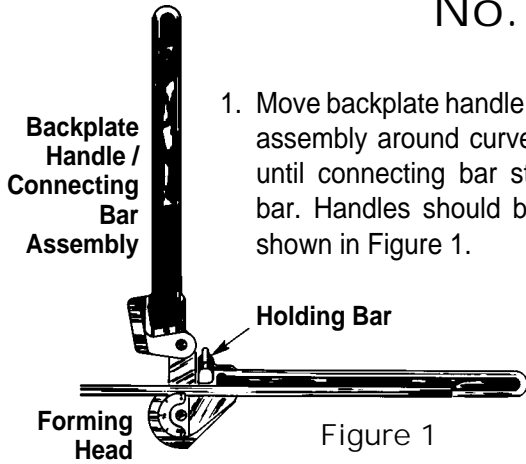

1. Move backplate handle / connecting bar assembly around curved forming head until connecting bar stops on holding bar. Handles should be positioned as shown in Figure 1.

Figure 1

2. Position tubing (sizes 3/16", 1/4", 5/16", or 3/8") in appropriate sized groove on forming head and holding bar. Tubing will start bending at the zero calibration point on forming head.
3. Rotate backplate handle until contact is made with tubing, and the calibration marks align at zero. See Fig. 2.

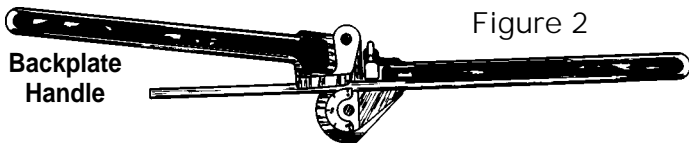

Figure 2

4. Move backplate handle around forming head until desired angle is attained as indicated by the alignment of the calibration marks. See Figure 3.

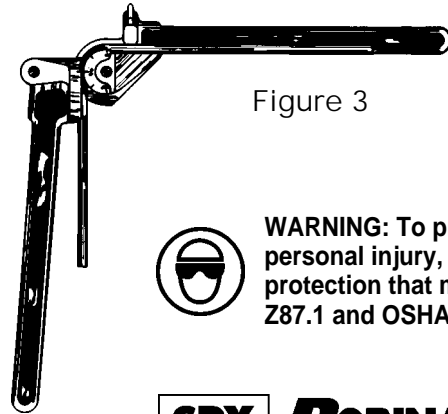

Figure 3



WARNING: To prevent personal injury, wear eye protection that meets ANSI Z87.1 and OSHA standards.

SPX ROBINAIR

SPX Corporation
655 Eisenhower Drive
Owatonna, MN 55060-0995
Technical Services: 1-800-822-5561
Fax: 1-800-822-7805
Customer Service: 1-800-533-6127
Fax: 1-800-322-2890
Website: www.robinair.com

Design, specifications, and materials are subject to change without notice.