



SPX Corporation
 655 Eisenhower Drive
 Owatonna, MN 55060-0995 USA
 Phone: (507) 455-7000
 Tech. Serv.: (800) 533-6127
 Fax: (800) 955-8329
 Order Entry: (800) 533-6127
 Fax: (800) 283-8665
 International Sales: (507) 455-7223
 Fax: (507) 455-7063

Form No. 102781

**Parts List &
 Operating Instructions**
 for:

1821

**Automotive
 Oil Filter Crusher**

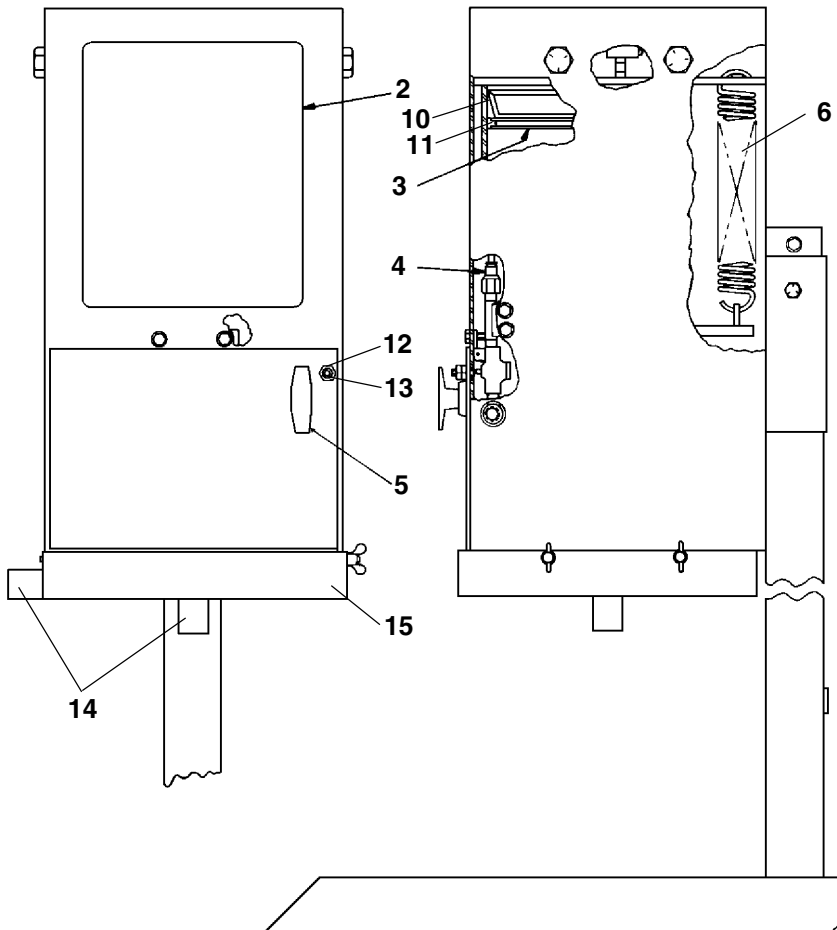
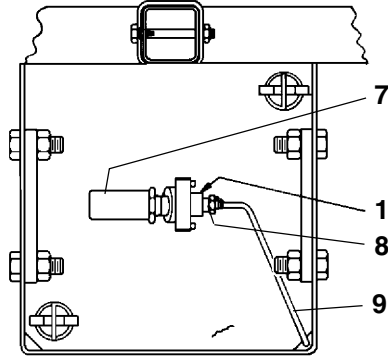

Item No.	Part No.	No. Req'd.	Description
1	223530	1	Exhaust Valve
2	223517	1	Decal
3	223531	1	Piston Weldment
4	223532	1	Valve Assembly
5	223533	1	Vise Action T-handle
6	520819	1	Return Springs
7	525184	1	Muffler
8	525185	1	Male Adapter
9	525187	1	17" Long Tubing
10	525188	1	Packing
11	525189	2	Wiper Ring, Half
12	525191	1	Hex Jam Nut
13	525192	1	Set Screw
14	525193	2	3/4-14 NPT Plug
15	525195	1	Tray

Refer to any operating instructions included with the product for detailed information about operation, testing, disassembly, reassembly, and preventive maintenance.

Items found in this parts list have been carefully tested and selected by OTC. **Therefore: Use only OTC replacement parts!**

Additional questions can be directed to the OTC Technical Services Dept.

Translations added.

Safety Precautions



CAUTION: To prevent personal injury and/or equipment damage,



- Read and follow the operating instructions supplied with this oil filter crusher.
- Do not modify this machine, or alter the operation in any way to circumvent the interlocking door mechanism. Modifications to the machine will void warranties, expressed or implied.



- Wear protective eyewear that meets ANSI Z87.1 and OSHA standards.
- Install the unit on a level, concrete floor.
- This machine is designed for crushing spin-on oil filters, and cartridge oil filters with paper elements. Do not use this machine to perform any operations other than to crush oil filters; do not crush aerosol cans, or cylinders of compressed gas; do not crush fuel filters, or containers of flammable liquids such as solvents or paint thinners.



- Do not stack oil filters inside the crushing chamber.
- Do not open the shield until the cycle is complete and the unit shuts off. Do not remove or modify the shield.

- Remove the crushed filter carefully. Sharp edges can scratch, cut, or puncture skin.
- Clean up spilled oil immediately, so it does not create a safety hazard.
- Inspect the crusher on a regular basis. If the unit is subjected to an abnormal load or shock, it should be inspected immediately. Should the unit appear to be damaged, or operate abnormally, discontinue use until necessary repairs are made.

Assembly Instructions

1. Locate a suitable place in your shop to install the No. 1821 – indoors on a level, hard surface. We recommend anchoring the crusher to a concrete floor.
2. The crusher is shipped in the lowered position. Position the crusher in the desired location in your shop. Mark the floor for the anchor bolt location to match the holes in the base of the stand. (Use four 3/8" or 1/2" diameter anchor bolts.) Install the anchor bolts, and secure the crusher to the floor.
3. Remove the bolt and nut from the stand post, but do not remove the 5/16 inch screw from top of the post.
4. Raise the crushing module from the shipping position to the working position.



CAUTION: The crushing module weighs 210 lbs.; to prevent personal injury, use a shop crane or lift truck to perform the lifting.

5. Align the hole in the crushing module tube with the hole in the stand post, and insert the bolt provided. Tighten the nut on the bolt.
6. Connect the catch basin to an appropriate waste oil container as required by national, state, or local regulations. The catch basin connection is a 3/4 FNPT fitting located on the bottom or on the side. If the opposite side connection is desired, simply remove the catch basin and install with the connection on the desired side.

The crusher may be connected to a remote waste oil tank by using a 3/4" male pipe. Another option is to connect the catch basin to a drum. Use a 3/4" pipe nipple, a 1" I.D. oil resistant hose, and a hose clamp to connect the hose to the catch basin. Install the hose in the bung of the drum, and cut the length of the hose to fit in the drum at least 2"–4". The installation must provide for the easy removal of the catch basin for cleaning.

Assembly Instructions contd.

7. Connect the air supply to the air inlet—the inlet connection is 1/4 FNPT. Minimum operating air pressure is 100 PSI for most car and light truck filters; maximum air pressure is 200 PSI.
8. If for any reason the crusher does not operate correctly after reviewing these steps, consult the Troubleshooting section in these instructions, or call Technical Services (1-800-533-6127) for further instructions and assistance.

Operating Instructions

1. Place the oil filter, with the open end down, in the center of the crushing chamber.
2. Close the door and turn the handle 180° clockwise (CW). Listen for the air to stop flowing (up to 45 seconds). You will also hear some noise and vibration.
3. To remove the crushed filter, turn the handle counterclockwise (CCW), and air will exhaust from the cylinder. The door will not open until the ram is fully retracted (approximately 10 seconds). Open the door and remove the crushed oil filter.
4. Recycle or dispose of waste oil and oil filters according to local, state, and federal regulations.

Note: The set screw on the door, which actuates the control valve and the pawl on the handle latch, is preset at the factory and should never need adjustment. For assistance, call Technical Services at 1-800-533-6127.

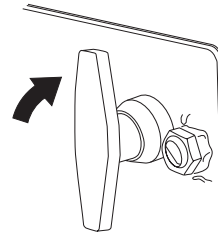

Door closed, handle turned fully clockwise (CW): door is latched, ram extends.

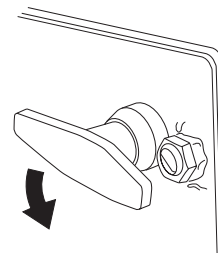

Door closed, handle turned 90° counterclockwise (CCW): air exhausts, ram retracts, door remains closed.

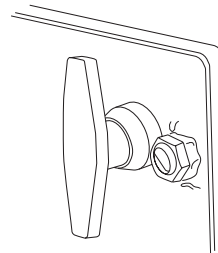

Handle turned fully counterclockwise (CCW): door opens.

Preventive Maintenance

1. Inspect the door for closure and handle latching operation.
 - A. The door should close easily, and the handle should loosely latch with a 90° rotation of the handle.
 - B. Another 90° rotation of the handle should clamp the door shut and actuate the control valve. You should hear the sound of air flowing for up to 45 seconds until the ram is fully lowered and the air pressure in the cylinder equalizes with air supply.
 - C. After the unit stops, check for excessive leaks. (A leak is excessive if it can be heard; it will then degrade the performance of the machine.) Minor leaks do not adversely affect the operation of the machine.
 - D. Unlatch the door, and air should exhaust from the cylinder. The door should not open until the ram has returned to its fully retracted position (approximately 10 seconds).
2. Inspect the crushing chamber for damage or worn parts. Clean and/or remove sludge or foreign objects from the crushing chamber.
3. Remove the catch basin, and clean out the sludge, semi-solid waste, and foreign material. Make sure the outlet of the catch basin is clear. The oil level in the catch basin can be viewed through the opening beneath the door when the door is closed.
4. Verify all instruction and warning labels are readable and complete. Wash external surfaces of the machine with a low pressure soap solution.

Sheet No. 2 of 2

Issue Date: Rev. D, 5-20-04

Troubleshooting

 **WARNING:** To prevent personal injury, repair work or troubleshooting must be performed by qualified personnel who are familiar with this equipment.

The following are common problems and solutions. If the solution listed fails to correct the problem, call Technical Services at 1-800-533-6127.

Problem	Cause	Solution
Ram does not actuate.	<ol style="list-style-type: none"> 1. Not connected to air supply. 2. Set screw on door is not correctly actuating the control valve. 	<ol style="list-style-type: none"> 1. <i>Connect unit to adequate air supply (see Assembly Instructions).</i> 2. <i>Call Technical Services at 1-800-533-6127.</i>
Crushing action is inadequate.	<ol style="list-style-type: none"> 1. Air pressure too low. Some brands or models of oil filters are stronger than other brands and therefore will not crush as flat. 2. Excess air leakage. 3. Crushing too many filters at one time, or there is too much height difference in the filters you are crushing at one time. 	<ol style="list-style-type: none"> 1. <i>100 psi will adequately crush most car and light truck filters.</i> 2. <i>Locate source of leak(s) and repair.</i> 3. <i>Crush multiple filters of similar heights or crush filters individually.</i>
Oil is running over the catch basin.	<ol style="list-style-type: none"> 1. The outlet of the catch basin is clogged. 	<ol style="list-style-type: none"> 1. <i>Remove the catch basin and clean out the accumulation.</i>