



SPX Corporation
 655 Eisenhower Drive
 Owatonna, MN 55060-0995 USA
 Phone: (507) 455-7000
 Tech. Serv.: (800) 533-6127
 Fax: (800) 955-8329
 Order Entry: (800) 533-6127
 Fax: (800) 283-8665
 International Sales: (507) 455-7223
 Fax: (507) 455-7063

Form No. 102737

Parts List &
 Operating Instructions
 for:

1728
 014-00942

High Lift Transmission Jack

Max. Capacity: 1,000 lbs. at 90 PSI

525197
 Head Assembly

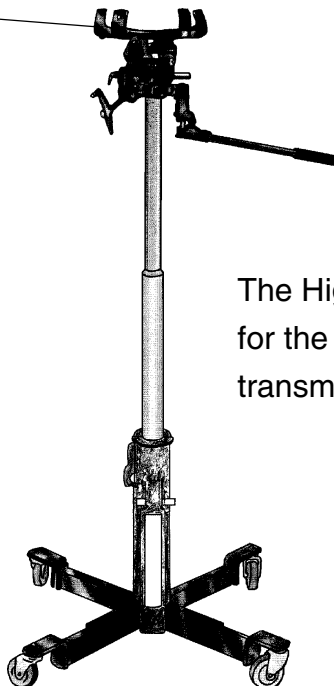

The High Lift Transmission Jack is designed for the installation and removal of automobile transmissions.

Safety Precautions



CAUTION: To prevent personal injury and damage to equipment,



- Read, understand, and follow all instructions, including the ANSI B30.1 safety code for jacks.

- Wear eye protection that meets the requirements of ANSI Z87.1 and OSHA.

- Inspect the jack before each use; do not use the jack if it's damaged, altered, or in poor condition.

- A load must never exceed the rated lifting capacity of the jack.

- Use the jack on a hard, level surface.

- Never move the jack with a load any higher off the ground than necessary. **SLOWLY AND CAREFULLY** move the jack around corners, because the load could tip.

- Do not modify the jack or use adapters unless approved or supplied by OTC.

- Lower the jack slowly and carefully while watching the position of the load.

- Use only approved hydraulic fluid (Chevron AW Hydraulic Oil MV or equivalent). The use of alcohol, hydraulic brake fluid, or transmission oil could damage seals and result in jack failure.

This guide cannot cover every situation, so always do the job with safety first.

Shaded areas reflect the last revisions made to this form.

Sheet No. 1 of 5

Issue Date: Rev. D, 03-04-04

Operating Instructions

This is a two-stage transmission jack. The air stage is designed to quickly move the adapter into position, and is completed with an automatic lock function that prevents loss of load. The following hydraulic stage is designed to align the adapter with the transmission.

1. Lift the vehicle on a hoist.
2. Position the jack under the transmission.
3. Connect the air supply to the jack. (90 psi of clean, dry air is required for the capacity of this jack.)
4. Press the pedal marked UP to raise the adapter until the cylinder locks into place (at about 20 inches). The air hose can be removed at this time.



CAUTION: If a load is transferred to the adapter when the air cylinder is only partially raised, the cylinder will drop suddenly. To eliminate this problem, always raise the cylinder to the point where the mechanical lock engages.

5. Check the placement of the jack. The transmission's center of weight, or balance point, should be centered over the jack adapter, with the power output end located over the adapter bracket between the chains. The jack's mechanical lock must be engaged.
6. Close the hydraulic release valve by turning the knob clockwise (CW).
7. Pump the jack handle to finish raising the adapter to the transmission. Use the controls on the adapter to roll or tip the adapter as needed to align it with the transmission.
8. Push in the four adapter brackets until they touch the transmission. Use the chains to secure the transmission to the adapter.
9. Support the engine, and remove the transmission according to instructions in the vehicle service manual.
10. Slowly turn the hydraulic release valve counterclockwise to lower the hydraulic stage. Lower the air stage by pressing the DOWN foot pedal. If the load is already resting on the mechanical lock, attach the air hose, and press the UP pedal briefly so the mechanical lock will release. The air stage should then lower when the DOWN pedal is pressed.

Bleeding Air from the Hydraulic System

Air can accumulate within a hydraulic system during shipment or after prolonged use. This entrapped air causes the jack to respond slowly or feel "spongy." To remove the air:

1. Tilt the jack onto two casters with the pump handle positioned below the cylinder.
2. Open the release valve by turning the knob counterclockwise (CCW).
3. Pump the handle until resistance is felt.
4. Close the release valve by turning the knob all the way clockwise (CW).
5. Continue pumping the handle while returning the jack to its upright position.

Jack Assembly

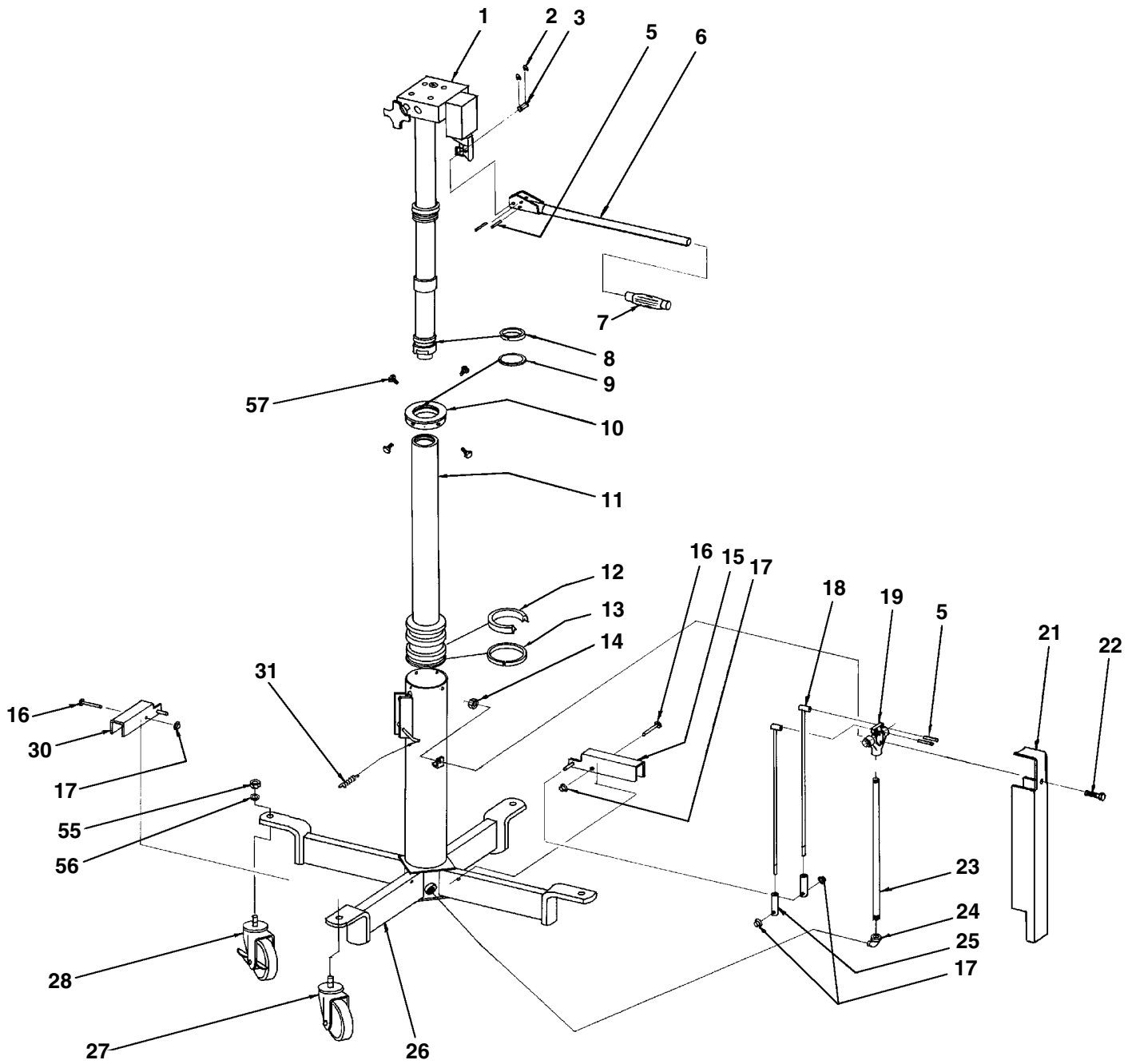

Shaded areas reflect the last revisions made to this form.

525197 Head Assembly

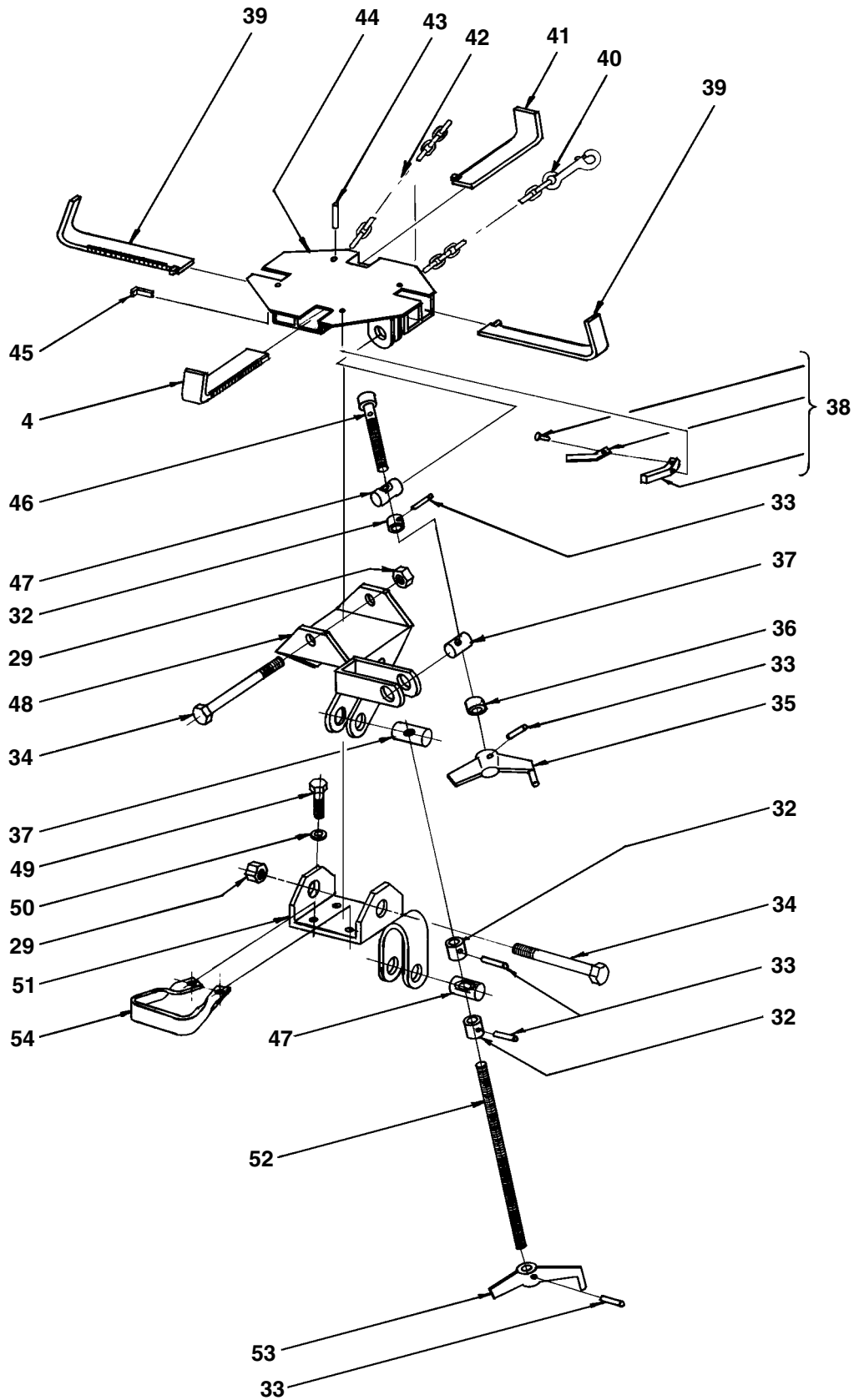

Shaded areas reflect the last revisions made to this form.

Hydraulic Unit

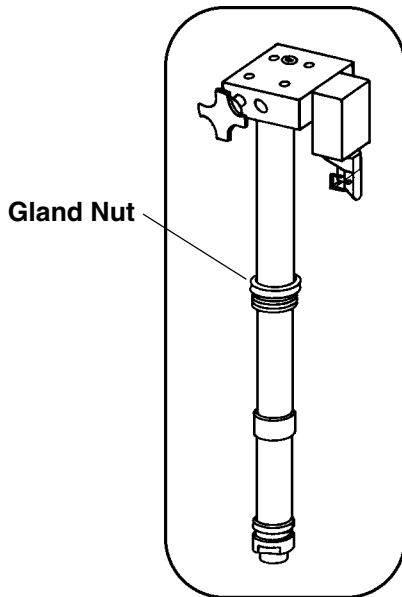

If the hydraulic unit needs service, it can be removed easily for repair or shipment to a manufacturer-approved service center. If the unit is shipped, remove the platform assembly and handle to minimize package size and weight. The hydraulic unit will separate from the jack by removing the **gland nut**.

Hydraulic Unit Detail

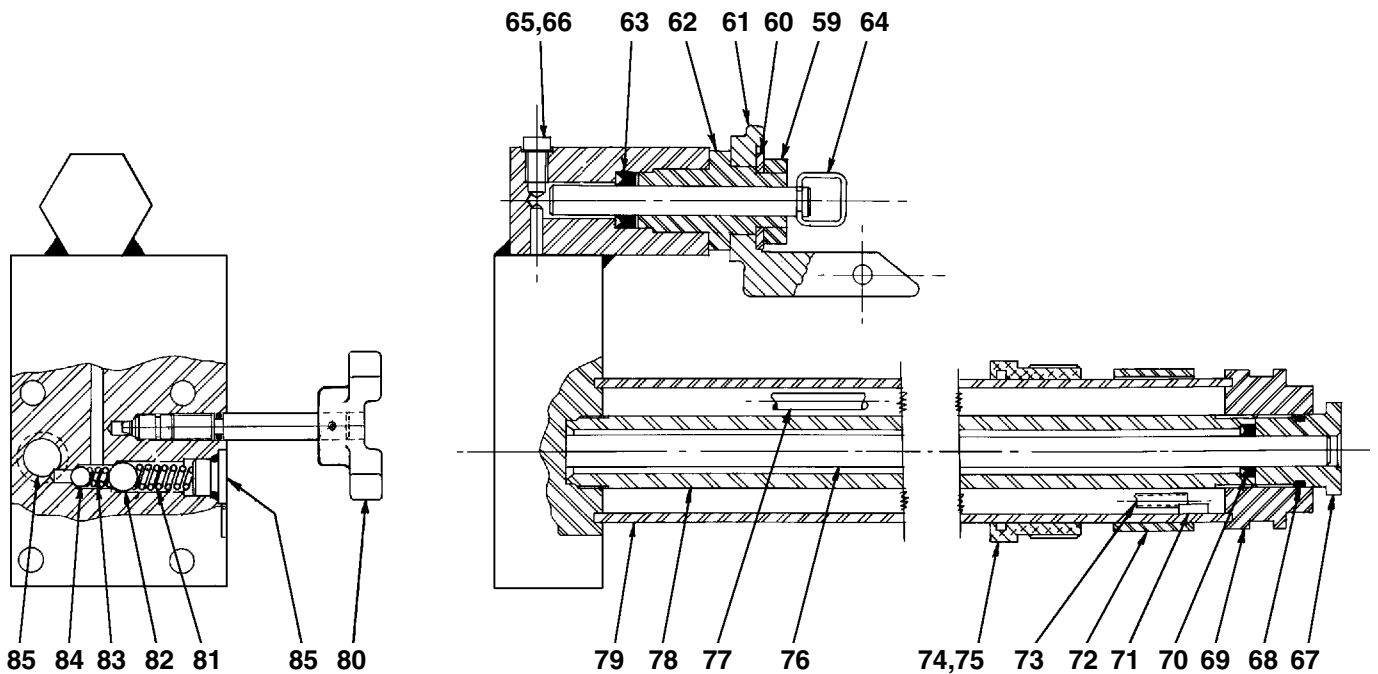

Refer to any operating instructions included with the product for detailed information about operation, testing, disassembly, reassembly, and preventive maintenance.

Items found in this parts list have been carefully tested and selected by OTC. **Therefore: Use only OTC replacement parts!**

Additional questions can be directed to the OTC Technical Services Department.

Item No.	Part No.	No. Req'd	Description
1	1728-01	1	Hydraulic Unit
2	1728-02	2	Retaining Ring (1/8")
3	1728-03	1	Pump Shaft
4	1728-04	1	Transmission Bracket
5	✓ 1728-05	4	Roll Pin (1/4" x 1-1/2")
6	1728-06	1	Pump Handle Rod
7	1728-07	1	Handle Grip (7/8" ID)
8	◆ 1728-08	1	Wiper Ring (2")
9	◆ 1728-09	1	Felt Ring (2-3/4" OD)
10	1728-10	1	Gland Nut (4" bore; <i>for serial no. 83-225639 and below</i>)
	507530	1	Gland Nut (4" bore; <i>for serial no. 83-225640 and above</i>)
11	1728-11	1	Piston Rod (<i>for serial no. 83-225639 and below</i>)
	507531	1	Piston Rod (<i>for serial no. 83-225640 and above</i>)
12	◆ 1728-12	1	Seal (4" dia.)
13	◆ 1728-13	1	Ring Wiper (4" bore)
14	1728-14	1	Self-locking Nut (1/4"-20)
15	1728-15	1	Pedal (UP)
	517189	1	Pedal (UP) (<i>for serial no. 48-020001 and above</i>)
16	1728-16	2	Rivet (1/4" x 1-3/4")
17	1728-17	4	Palnut (1/4")
	517190	4	Palnut (1/4") (<i>for serial no. 48-020001 and above</i>)
18	1728-18	2	Control Rod
	517186	2	Control Rod (<i>for serial no. 48-020001 and above</i>)
19	1728-19	1	Air Valve
21	1728-21	1	Valve Cover
22	1728-22	1	Cap Screw (1/4" x 1-3/4")
23	1728-23	1	Pipe (1/4" x 14-3/4")
24	1728-24	2	Street Elbow (1/4")
25	1728-25	2	Rod End
	517187	2	Rod End (<i>for serial no. 48-020001 and above</i>)
26	1728-26	1	Base Weldment
27	1728-27	2	Caster (4")
28	1728-28	2	Caster w/ Brake (4")
29	1728-29	2	Self-locking Nut (1/2"-13)
30	1728-30	1	Pedal (DOWN)
	517188	1	Pedal (DOWN) (<i>for serial no. 48-020001 and above</i>)
31	1728-31	1	Spring
32	1728-32	3	Drilled Spacer
33	1728-33	5	Roll Pin (3/16" x 7/8")
34	1728-34	2	Cap Screw
35	1728-35	1	Side Tilt Crank
36	1728-36	1	Spacer (not drilled)
37	1728-37	2	Tilt Nut
38	1728-38	4	Ratchet Assembly
39	1728-39	2	Transmission Bracket (long)
40	1728-40	1	Chain & Snap Assembly
	517191	1	Strap Assembly (<i>for serial no. 48-020001 and above</i>)
41	1728-41	1	Transmission Bracket (short)
42	1728-42	1	Chain (1/0; 42 links)
	517192	1	Cap Screw & Washer (<i>for serial no. 48-020001 and above</i>)
43	1728-43	4	Roll Pin (1/4" x 7/8")
44	1728-44	1	Adapter Weldment
45	1728-45	3	Angle Stop

Item No.	Part No.	No. Req'd	Description
46	1728-46	1	Side Tilt Shaft
47	1728-47	2	Tilt Trunnion
48	1728-48	1	Pivot Bracket
49	1728-49	4	Cap Screw (3/8" x 1)
50	1728-50	4	Lockwasher (3/8")
51	1728-51	1	Hydraulic Unit Bracket
52	1728-52	1	Long Tilt Shaft
53	1728-53	1	Crank (lower)
54	1728-54	1	Tow Handle
55	1728-55	4	Hex Jam Nut (1/2")
56	1728-56	4	Lockwasher (1/2")
57	1728-57	4	Self-locking Cap Screw (3/4" long)
59	✓ 1728-59	1	Jam Nut (3/4"-1 6 UNF)
60	✓ 1728-60	1	Rim Washer
61	1728-61	1	Swivel Pivot
62	✓ 1728-62	1	Pump Sleeve
63	✓*◆ 1728-63	1	Seal (13/16" OD x 7/16" ID x 1/4" deep)
64	✓* 1728-64	1	Plunger Weldment
65	1728-65	1	Soc. Hd. Cap Screw (5/16"-18 UNC)
66	1728-66	1	Metallic Gasket
67	1728-67	1	Ram Guide
68	◆ 1728-68	1	O-ring (1" OD x 3/16" ID x 3/32" dia.)
69	1728-69	1	Cap
70	◆ 1728-70	1	Seal (11/16" OD x 7/16" ID x 3/16" deep)
71	1728-71	1	Magnet
72	1728-72	1	Spacer <i>(for serial no. 83-225639 and below; not needed for serial no. 83-225640 and above)</i>
73	1728-73	1	Suction Tube (22-5/8" long)
74	◆ 1728-74	1	Felt Packing Gasket
75	1728-75	1	Packing Gland (2" bore; <i>for serial no. 83-225639 and below</i>)
	507532	1	Packing Gland (2" bore; <i>for serial no. 83-225640 and above</i>)
76	1728-76	1	Ram
77	1728-77	1	Suction Tube (6" long)
78	1728-78	1	Cylinder Tube
79	1728-79	1	Reservoir Tube
80	1728-80	1	Release Knob Sub-assembly
81	1728-81	1	Compression Spring (.406 OD)
82	1728-82	1	Ball (3/8" dia. RC)
83	1728-83	1	Compression Spring (.250 OD)
84	1728-84	1	Ball (1/4" dia. RC)
85	1728-85	2	Plug w/ o-ring
			Available Kits
	221089	1	Two-piece Plunger Kit (items marked with *)
	221088	1	Complete Plunger Kit (items marked with ✓)
	221090	1	Soft Seal Kit (3") (items marked with ◆)
	525797	1	Head Assembly

221598 Adapter Set
(used on 014-00942)

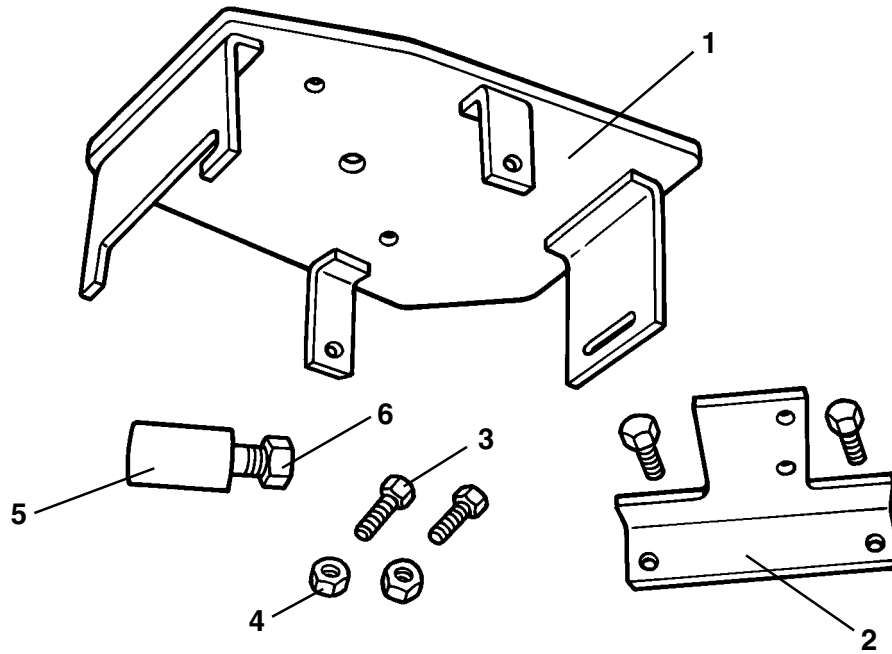

Item No.	Part No.	No. Req'd	Description
1	54370	1	Adapter
2	313559	1	Mounting Bracket
3	16469	4	Cap Screw
4	10204	2	Hex Nut
5	221597	1	Stem
6	10208	1	Hex Nut

Maintenance

Adding Oil to the Hydraulic Stage (See Figure 1)

1. Position the jack upright with all four casters on the floor. Lower the hydraulic stage.
2. Remove the transmission adapter by removing the four bolts holding it to the jack.
3. Clean the top of the jack, concentrating on the area around the filler plug.
4. Remove the release knob. This serves as a vent while the reservoir is being filled.
5. Remove the filler plug.
6. Slowly add Mobile DTE #11 oil (or equivalent) until the reservoir overflows.
7. Install the release knob.
8. Install the filler plug, and mount the adapter.

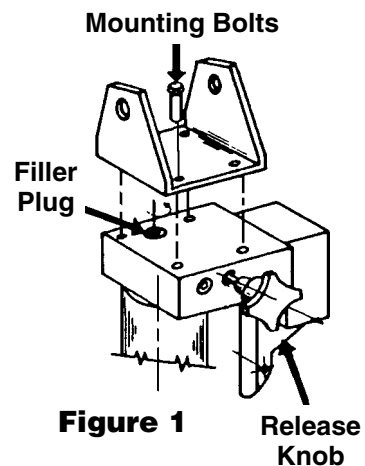

Cleaning the Air Control Valve (Item numbers refer to Figure 2)

1. Remove the fittings (1) from the ends of the air control valve. Clean the screen.
2. Insert a nail or stiff wire into the center of the control body (3), and push each valve spool (2) out of the body.
3. Look for foreign matter embedded in the valve seals (4). If this is the case, remove the screw (5) and cup (6) from the end of the spool, clean the seat, turn it over, and reassemble.
4. Lubricate the valve spool with light chassis grease.
5. Assemble the valve in this order: insert the valve spools; insert the springs; assemble the hexagon fittings into the body.

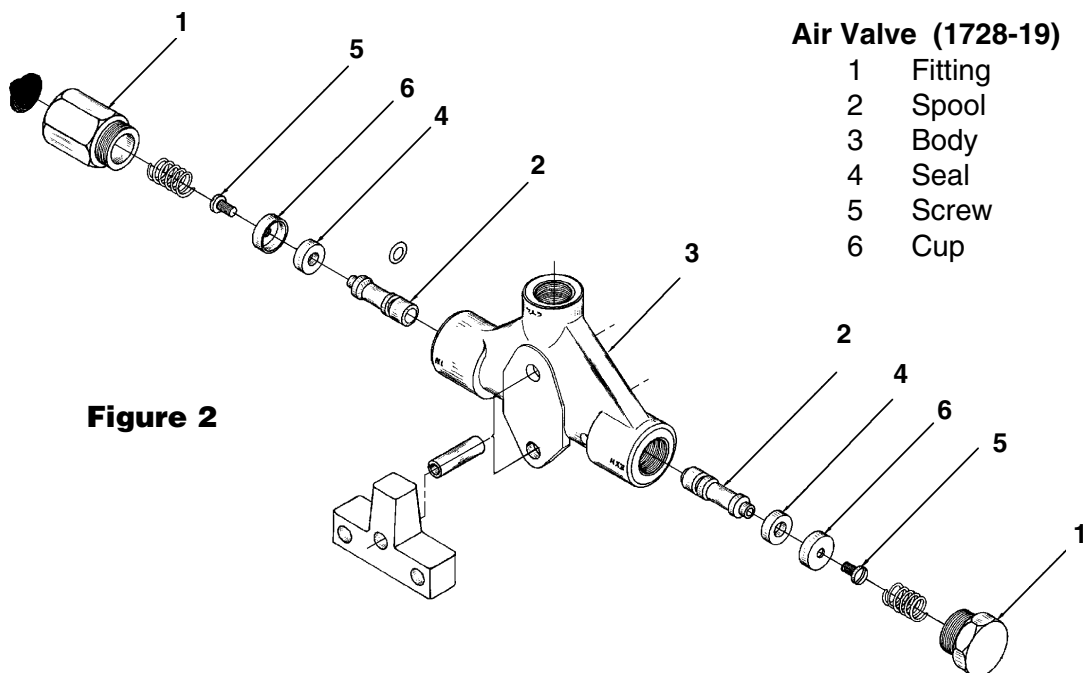

Preventive Maintenance

IMPORTANT: The greatest single cause of failure in hydraulic units is dirt. Keep the transmission jack clean and well lubricated to prevent foreign matter from entering the system. If the jack has been exposed to rain, snow, sand, or grit, it must be cleaned before it is used.

1. Store the jack in a well-protected area where it will not be exposed to corrosive vapors, abrasive dust, or any other harmful elements.
2. Lubricate moving parts at least once per month.
3. Regularly wipe the cylinder columns with a clean cloth to remove dirt and abrasives.
4. Replace the oil in the reservoir at least once per year.
5. Inspect the jack before each use. Take corrective action if any of the following problems are found:

a. Cracked or damaged housing	d. Scored or damaged piston rod
b. Excessive wear, bending, or other damage	e. Loose hardware
c. Leaking hydraulic fluid	f. Modified or altered equipment

Troubleshooting Guide

Repair procedures must be performed in a dirt-free environment by qualified personnel who are familiar with this equipment.

Trouble	Cause	Solution
Air Stage - Air leak causes mechanical lock to engage or erratic cylinder action	1. Air valve is dirty	<i>1. Follow instructions to clean air valve.</i>
Air Stage - Cylinder does not lower when DOWN pedal is pressed	1. Mechanical lock is engaged	<i>1. Attach air hose and press UP pedal until cylinder is at full line pressure. Press DOWN pedal and mechanical lock should release.</i>
Hydraulic Stage - Cylinder does not raise	1. Jack is out of prime	<i>1. Follow instructions on bleeding air from the hydraulic system.</i>
Hydraulic Stage - Cylinder lifts load, but doesn't hold	1. Release valve is not sealing 2. System oil is dirty	<i>1. Clean or reseal release valve ball. 2. Replace hydraulic oil.</i>
Hydraulic Stage - Cylinder does not raise to full height	1. Low oil level	<i>1. Check oil level. Follow instructions on adding oil.</i>