

StrutTamer HD

SUVs and Light Trucks

Simply the most effective compressor for virtually any straight, conical, or offset spring.

- Four-point locking jaws securely hold the spring in place.
- Open-ended design means you can take the strut in and out, quickly and easily.
- The arms adjust in and out, up and down, to accept many sizes of springs.
(2-1/2" to 10" diameter)
(2-1/2" to 24" vertical stroke)
- Extra long 3-bar handle gives user the leverage needed to compress the big strut springs.
- No need to change shoes for different size springs.
- Easy to transport when mounted on optional stand (No. 6586 – StrutTamer HD with stand; No. 6582 – stand only).
- Comes with No. 6583 Bridge accessory to be used on springs that cannot be compressed enough to remove the retaining nut.

No. 6586

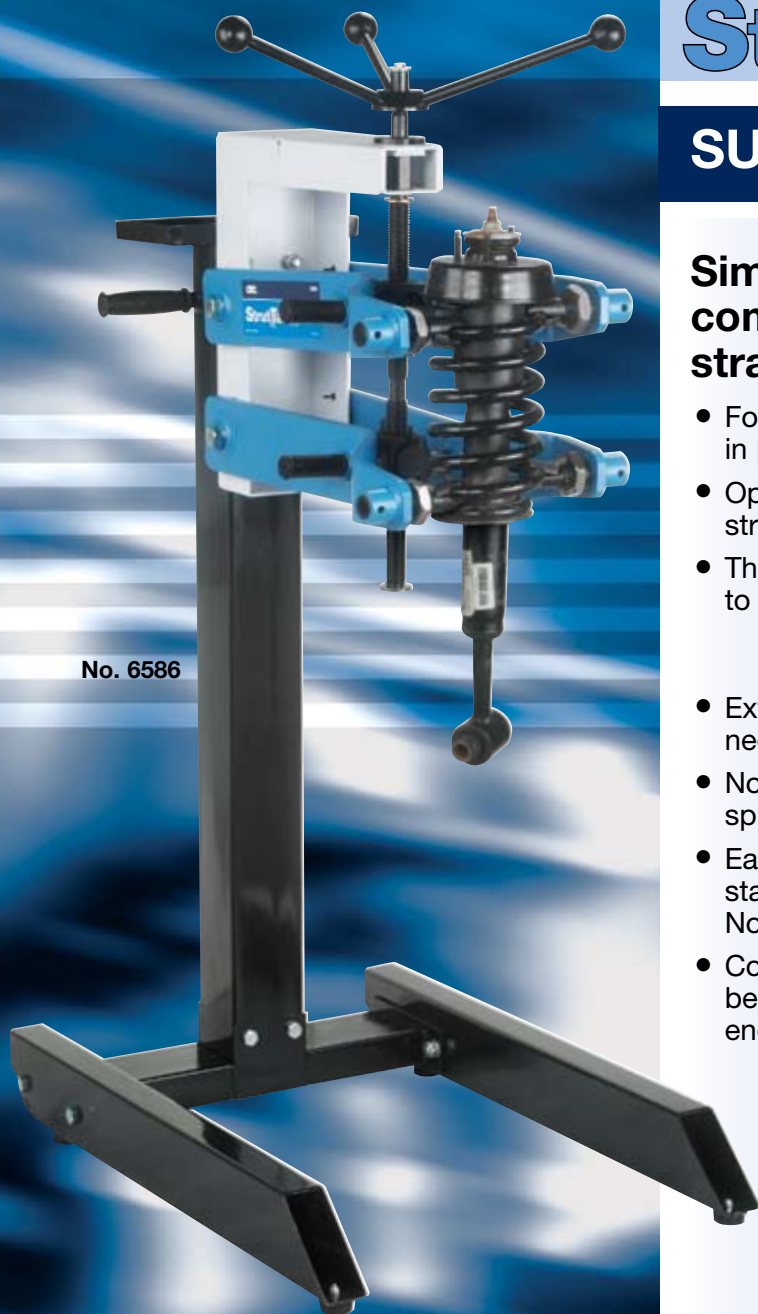

PATENTED
U.S. 6,719,305 / 6,129,339



No. 6583



Thicker arms with 4-point locking jaws securely hold the larger springs in place.

OTC's Heavy-Duty StrutTamer for SUV and Light Truck Strut Springs

StrutTamer HD

OTC's StrutTamer HD for strut springs. This is simply the most effective compressor for handling virtually any straight, conical, or offset spring. With its adjustable arms and four-point locking jaws, the StrutTamer HD securely holds the spring in place.

To keep the strut assembly straight during compression, we've developed a center screw that floats from side-to-side. This way the strut and spring remain aligned – no matter what condition the spring is in. The StrutTamer HD also features an extra long 3-bar handle crank with the needed leverage to compress heavy-duty springs faster and easier. The StrutTamer HD can easily be mounted to the wall without the need for adapters, or you can choose the optional stand.

The OTC StrutTamer HD stand features steel frame construction with two wheels that allow you to easily tilt the stand back and move the entire unit to the work area. The stand's narrow design allows for easier mobility between vehicles in the shop. During compression, the wheels lift off the floor, and four no-slip rubber pads keep the stand firmly in place.

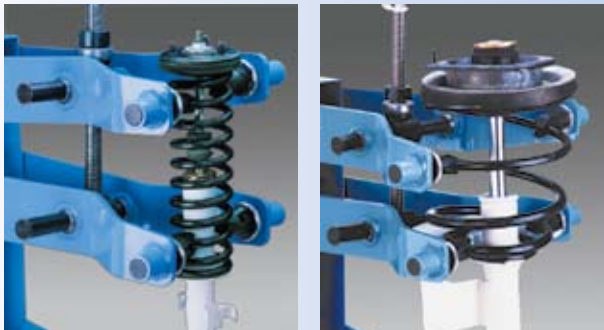
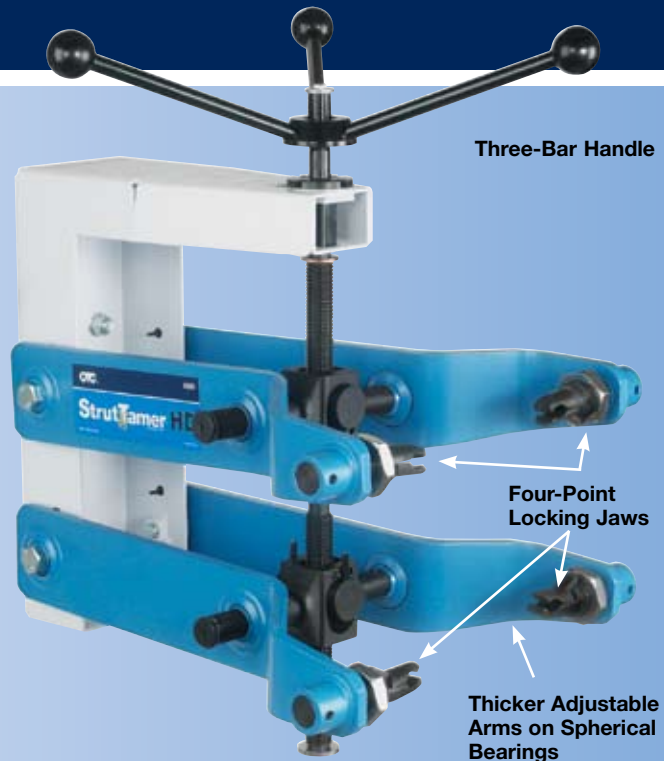

Strut Spring Coverage

2-1/2" to 10" spring diameters
2-1/2" to 24" vertical stroke range

No. 6585 – StrutTamer HD strut spring compressor. Wt., 82 lbs.

No. 6586 – StrutTamer HD. Includes StrutTamer spring compressor and mobile stand. Wt., 150 lbs.

No. 6582 – StrutTamer stand. Wt., 68 lbs.

No. 6583 – Bridge accessory.

No. 6587 – 2:1 reduction gearbox. Allows a 2:1 torque compression increase when compressing struts.

Note: 6585 and 6586 can both be shipped UPS.



06-83 Rev. ©2006 SPX Corporation. All rights reserved. Because of ongoing product improvements, we reserve the right to change design, materials, and specifications without notice. Product shipped may differ from photo(s) shown.



No. 6586
StrutTamer HD with stand
Height 54" (1372 mm) (36" without handle)
Width 22-1/2" (572 mm)
Depth 32" (813 mm)



No. 6585
StrutTamer HD
Height 29" (736 mm)
Width 21" (533 mm)
Depth 20" (508 mm)

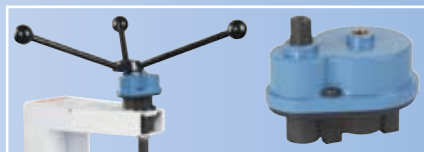

No. 6587 – 2:1 reduction gearbox. Allows a 2:1 torque compression increase when compressing struts.



No. 6582
StrutTamer Stand
Height 44" (1118 mm)
Width 22-1/2" (572 mm)
Depth 32" (813 mm)



No. 6583
Bridge Accessory